

Montage

1. Trägerklammer ansetzen, Spannschraube handfest anziehen (Kontermutter falls nötig zurückdrehen). Spannschraube festziehen: 1 bis max. 1½ Umdr.

Nennlast

Gruppe TCS 1: 5,0 kN

Diese Nennlasten gelten nur für neue TCS am unbeschädigten Trägerflansch.

2. Kontermutter festziehen.

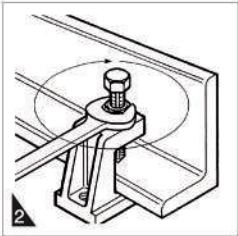

Installation

1. Position Beam Clamp. Hand-tighten clamping bolt (if necessary, unscrew the locking nut a bit). Tighten clamping bolt down with a spanner: 1 up to 1½ revolutions.

Max. working load (tension)
Group TCS 1: 5.0 kN

The nominal loads indicated apply to new Beam Clamps fixed to undamaged beam flanges only.

2. Tighten locking nut using a spanner.

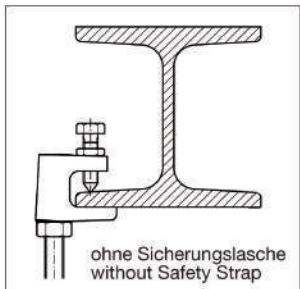

ohne Sicherungslasche
without Safety Strap

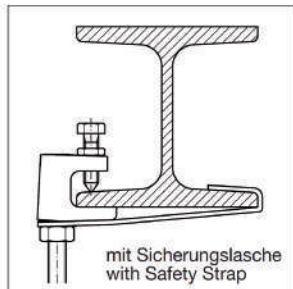

mit Sicherungslasche
with Safety Strap

Montagebeispiele
Mounting Examples

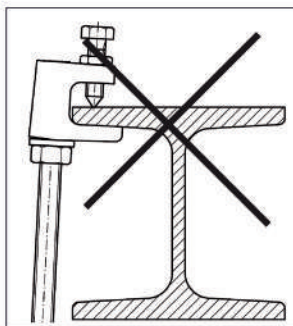
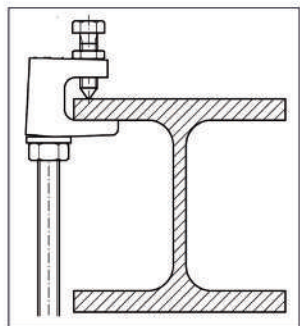

Achtung!

- ▶ Anordnung nur bei Parallelfanschträgern erlaubt.

Caution!

- ▶ This arrangement is permissible for parallel-flange beams only.

